



Rainbow SkyReach (Pty) Ltd

Hangar 27, Springs Airfield, Springs
P O Box 3408, 1544 Dalview
South Africa

Tel: +27 (0)11 817 2298

Fax: +27 (0)11 817 2297

E-mail: info@fly-skyreach.com

Web: www.fly-skyreach.com



6th September 2018

ALERT SERVICE BULLETIN

IMPORTANCE	High
AREA AFFECTED	Packed Parachute Assembly
SB NUMBER	CH/008/09-2018

Document contents:

- 1) Planning information
 - a) Affectivity
 - b) Reason for notice
 - c) Description of change
 - d) Compliance
 - e) Personnel qualification requirements
 - f) Weight and balance changes
 - g) Publications affected
- 2) Material information
 - a) Replacement parts
 - b) Required tooling
 - c) Required special tooling
- 3) Accomplishment instructions
 - a) General information
 - b) Work instructions
 - c) Final inspection

1) PLANNING INFORMATION

a) Affectivity:

Which aircraft it will affect?

- Aircraft with the BRS system installed.

b) Reason for notice:

During the final stages of the recent ground extraction testing in which BRS Aerospace approved the system installation on the Cheetah XLS/BushCat, a recommendation was made that an additional bridle be installed to provide extra distance between the aircraft and the parachute following deployment.

c) Description of change:

Instead of attaching the three aircraft harness loops directly to the quick link already secured to the top of the BRS U-frame on receipt; the provided "main bridle" harness section is attached to the top quick link, an additional quick link is attached to the bottom of the U-frame with tie wraps, and the other end of the main bridle harness and the three loops making up the aircraft harness are secured to the bottom loop.

The resulting change in assembly on deployment of the system is depicted in the schematic below:

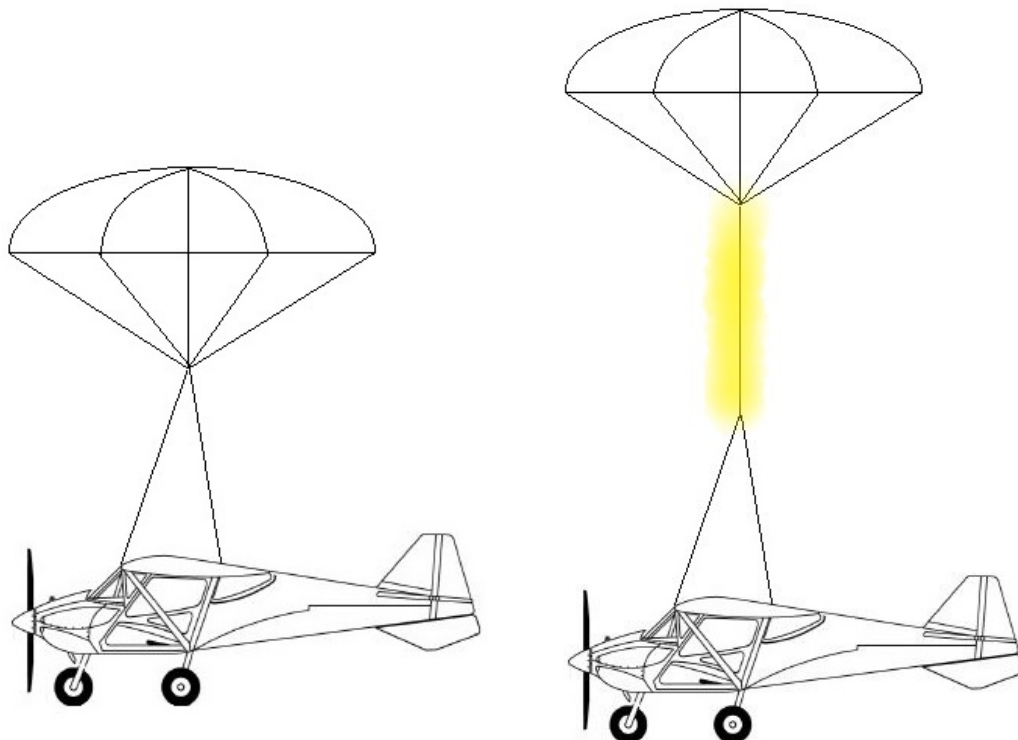

Schematic of BRS system deployed a) without and b) with the main bridle in place

d) Compliance:

Strongly recommended: This SB should be accomplished prior to the foreseen use of the BRS system. Continued flight is possible without the accomplishment of this SB, but use of the BRS system is not recommended without its accomplishment.

e) Personnel qualification requirements:

Any person qualified to maintain/repair the BushCat within the laws stipulated by the pertinent aviation authority regulations for the country of registration may carry out this service bulletin.

f) Weight and balance changes:

No change to the weight and balance.

g) Publications affected:

SKYREACH-BRS-PIM-02

2) MATERIAL INFORMATION

a) Replacement parts

1. 1 x Main Bridle Harness sections (BRS Part No. 007195-13, Bridle, Kevlar C-C end),
2. 1 x Quick Links, ½", FRENCH SS (BRS Part No. 005061-01)
3. Cable ties, plastic, 4 33/64", Black (BRS Part No. 004025-01)

b) Required tooling

Side cutters for the tie wraps, Loctite supplied with the original BRS kit and appropriate spanner set to loosen the Quick Links.

c) Required special tooling

Section of rubber fuel hose.

3) ACCOMPLISHMENT INSTRUCTIONS

a) General information

Caution: Prior to installation ensure that the pin is in the activation handle.

Caution: At no point must the parachute / rocket assembly be pulled away from the mounted activation handle sharply as this can activate the system.

b) Work instructions

Step 1

- Cut the tie wraps holding the aircraft harness S-fold together and securing it to the U-frame.
- Loosen and open the top quick link and remove all three aircraft harness ends.



Step 2

- Attach the ½” quick link (item BRS-12) using zip ties (item BRS-13) at the bottom of the tray (below the ½” quick link which is already attached).
- Insert 10mm sections of rubber fuel hose between the Quick Link and the metal U-frame.
- Tighten the zip ties as tight as possible and trim excess.



***NOTE:**

The Softpack may need to be removed from the tray to accomplish this step. Removal of the Softpack from the tray is done by detaching the four Velcro straps shown in Fig. 10. Secure the Softpack back to the tray before proceeding to the next step.

Step 3

- Connect one loop of the main bridle (item BRS-07) to the top ½” link (link that was already secured to the side of the tray) joining it to the parachute riser shown in Fig. 14. Close the link with a drop of Loctite® 242 blue on the threads.



Step 4

- S-Fold the main bridle (item BRS-07) in a clean manner such that the free “C” end can be attached to the bottom ½” quick link. Apply Loctite 242® blue to link threads and then close the link shown in Fig. 15. Secure the S-folds to using zip-ties (item BRS-13).



Step 5

- S-fold the 3 harnesses in a clean manner such that the 3 free “C” ends can also be attached to the bottom ½” quick link.
- Attach the three harness “C” ends of the front (item BRS-09) and rear harnesses (items BRS-08) to the bottom ½” quick link Apply Loctite 242® blue to link threads and then close the link shown in Fig. 16. Secure the S-folds using zip ties (item BRS-13).

WARNING! This step is of critical importance to the operation of the system. Double-check that the three harnesses and the parachute main bridle are attached to the bottom quick link for a total of four end loops.



c) Final inspection

1. Check that all quick links are tight.
2. Check that all excess harness is attached securely to the tray and cannot move / become entangled with itself or anything in its surrounds
3. Check that there is 1 harness end loop through the top Quick Link and 4 harness end loops through the bottom Quick Link.
4. On accomplishment, record of this service bulletin must be documented in the aircraft airframe logbook referencing the SB number.